

# SUPER STRONG WATER TANKS MADE FOR GENERATIONS



UV Protected



No Algae Growth

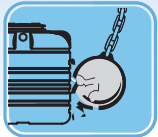

Super Strong



- ▶ Unique shape ensures equal pressure
- ▶ Improved stability
- ▶ Larger diameter against strong winds
- ▶ Highest number of ribs purposely made for maximize the strength
- ▶ Specially designed fittings

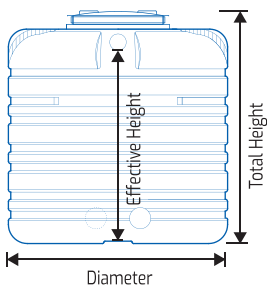

Available size	Available colours	Total Height	Effective Height	Overall Diameter
300 L	Black	980mm	790mm	700mm
500 L	Black	995mm	800mm	935mm
1,000 L	Black	1,255mm	1,115mm	1,160mm
2,000 L	Black	1,750mm	1,455mm	1,360mm

## UV Protected Outer Shell

Tough outer shell – impenetrable to falling objects

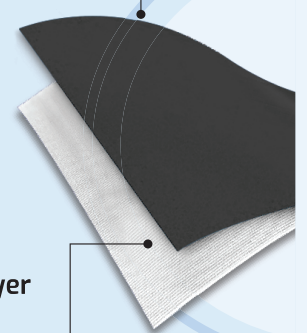

## Inner Hygiene Layer

Inner white color hygiene layer helps to show the water clarity



## St. Anthony's Industries Group (Pvt) Ltd.

No. 752/1, Dr. Danister De Silva Mawatha, Colombo 09, Sri Lanka.

Customer Care Support : +94 11 2680600

Email : support@anton.lk Web : www.anton.lk





# TANKS

Core of Hygenic Home!

## Why Anton Biocell?

Biocell recycling are safe, compact, reliable, and eco-friendly. It's playing an indispensable role in keeping the environment and ecosystem surrounding high-rise buildings, apartments, hotels, housing schemes, industrial zones, Public Toilet and service centers in coastal, hillside and low-lying areas, clean and healthy.

# Biocell Tanks

**SF-SEWER TREATMENT TANK**



**ST-SEPTIC TANK**



**FT-FILTER TANK**



### Benefits of the product

Best Solution for marshland and waterlogged lowlands. Great for small plots of land and can be used in both very small and spacious houses. Human waste does not accumulate in soil and can be safely stored. Groundwater is not contaminated. Since the outflow from the tank maintains an optimum COD and BOD level, its environment friendly even if it enters the reservoirs. By coupling the right size of FT and ST tanks system, it can be customized for any population. The best solution to the plague caused by germs released into the environment by toilets and also from floods.

**GT-GREASE AND OIL TRAP**



Keeps oil and grease separated from waste water

**SUMP TANK**



Drinking water can be stored underground, cleanly or safely.

# Functional Diagram

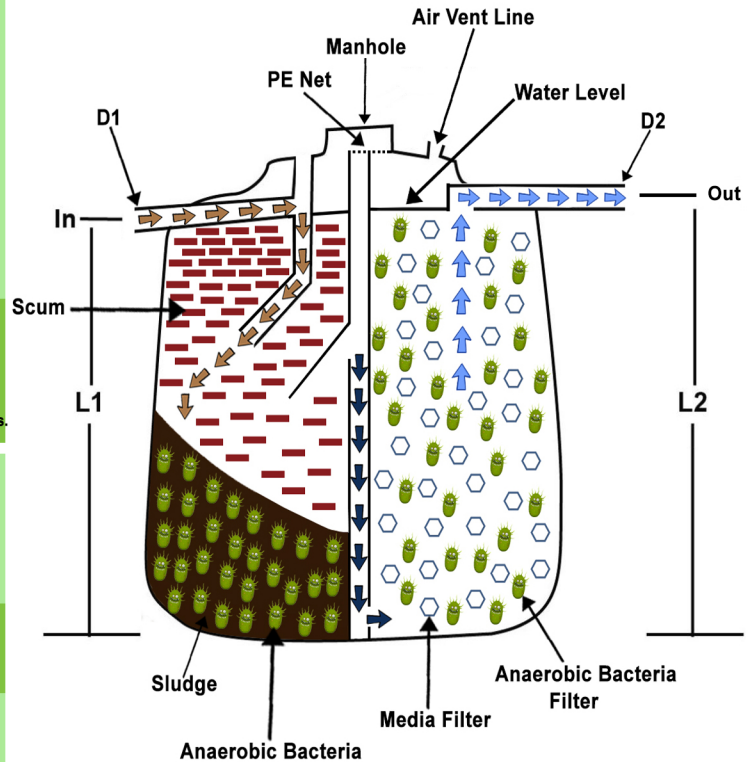

BIO CELL TANK CAPACITY	L1 (MM)	L2 (MM)	D1 (MM)	D2 (MM)	MAN HOLE DIAMETER (MM)
1000L	820	750	110	63	620
1600L	1265	1200	110	63	620
1800L	1460	1350	110	63	620
2000L	1580	1470	110	63	620
3000L	1490	1400	110	110	620
4000L	1870	1780	110	110	620
6000L	2370	2280	110	110	620



# Recommended Rated Capacities for Biocell Tanks

Model	Volume of tank (L)	Dimension		Number of user for 5 years
		Heights (mm)	Diameter (mm)	
SF 16	1600	1490	1430	4
SF 18	1800	1680	1475	5
SF 20	2000	1830	1475	6
SF 30	3000	1720	2100	10
SF 40	4000	2100	2100	14
SF 60	6000	2600	2100	18

FT 16	1600	1490	1430	18
FT 18	1800	1680	1475	22
FT 20	2000	1830	1475	25
FT 30	3000	1720	2100	41
FT 40	4000	2100	2100	57
FT 60	6000	2600	2100	78

ST 16	1600	1490	1430	6
ST 18	1800	1680	1475	7
ST 20	2000	1830	1475	8
ST 30	3000	1720	2100	12
ST 40	4000	2100	2100	20
ST 60	6000	2600	2100	26

GT 16	1600	1490	1430
GT 18	1800	1680	1475
GT 20	2000	1830	1475
GT 30	3000	1720	2100
GT 40	4000	2100	2100
GT 60	6000	2600	2100

SUMP TANK 16	1600	1490	1430
SUMP TANK 18	1800	1680	1475
SUMP TANK 20	2000	1830	1475
SUMP TANK 30	3000	1720	2100
SUMP TANK 40	4000	2100	2100
SUMP TANK 60	6000	2600	2100

## Special Note :

By Coupling the right size of FT and ST tanks system, it can be customized for any population.

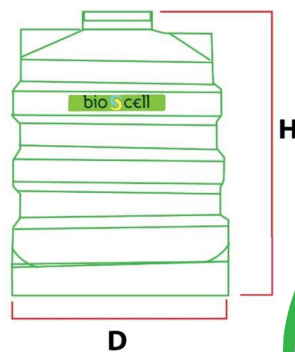

## Installation Diagram

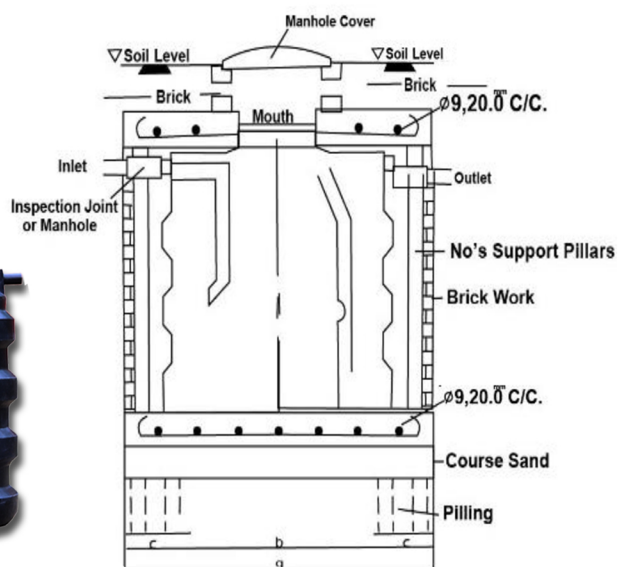

## St. Anthony's Industries Group (Pvt) Ltd.

No. 752/1, Dr. Danister De Silva Mawatha, Colombo 09, Sri Lanka.

Customer Care Support : +94 11 2680600

Email : support@anton.lk Web : www.anton.lk

Shanaka - 077 3360830



# WATER STORAGE TANKS AND BIO-CELL SEWER TREATMENT TANKS

## DOLPHIN WATER TANKS FOR STORAGE & TRANSPORTATION OF POTABLE WATER STORAGE TANKS



fig. 1



fig. 2

### DOLPHIN WATER TANKS

Table 1

Capacity (Litre)	Model	H - Height (mm)	D – Diameter (mm)	Fig.	Colour
5000	GW 50	1950	2120	12.1	BLACK
		1995	2022	12.1	BLACK
10000	GW 100	2860	2290	12.1	BLACK

### ANTON MAX POTABLE WATER STORAGE TANKS

#### MAX WATER TANKS

Table 2

Capacity (Litre)	Layers	H - Height (mm)	D – Diameter (mm)	Fig.	Colour
300	Double	969	669	12.2	Black/White
500	Double	969	925	12.2	Black/White
	Triple				Blue or Ivory/Black/White
1000	Double	1233	1156	12.2	Black/Black
	Triple				Blue or Ivory/Black/White
2000	Double	1733	1360	12.2	Black/Black
	Triple				Blue or Ivory/Black/White



## ADVANTAGES OF DOLPHIN AND DOLPHIN MAX TANKS

- \* Tank walls do not allow permeation of Oxygen avoiding fungus growth
- \* Moulded lid Made with virgin materials
- \* Specially designed inlet/outlet threaded nuts
- \* ESCR is high, as material is processed to avoid damaging the molecular structures.
- \* FDA approved material is used for Storing water
- \* Tanks designed with ribs to withstand higher and internal pressure

## SPECIAL FEATURES OF THE ANTON MAX TANKS

### THREE LAYER PROTECTION

- Strongest** - The 3 combined layers of HM HDPE/HDPE make ANTON MAX Triple the strongest water tank in the market (fig. 3)
- Most Hygienic** - Triple layer protection against algae growth keeps you healthy. The inner and outer layers made of 100% FDA approved virgin raw materials, ensuring non-contamination.
- Attractive appearance** - The aesthetically pleasing colour options add beauty to your home, allowing you to choose a colour, matching your home exterior,

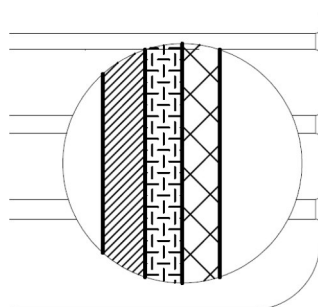

fig. 3

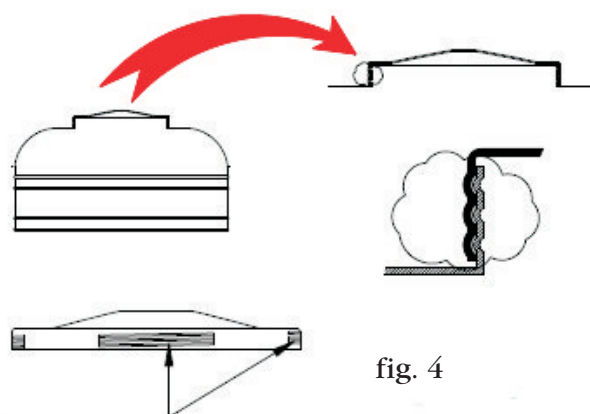

fig. 4

Partially Threaded lid

### OUTER LAYER

Made of an advanced raw material HM HDPE which forms a tough outer shell that's impenetrable to falling objects. Available in two specially designed colours - Sky blue and Ivory - that absorb less heat than black

Heat Absorption

Black - 97%

Sky blue - 50%

Ivory - 25%

### MIDDLE LAYER

Black in colour (Fig.5) with protection against UV rays. Acts as a secondary barrier against oxygen permeation and avoids algae growth. This retains the water quality same as the source.

## **INNER LAYER**

Made of virgin raw material. Its white colour, helps to show the water clarity.

## **THREADED LID**

The specially designed screw type lid dose not easily removed (fig 4)

## **GUIDELINES FOR PROPER INSTALLATION AND MAINTENANCE**

- a) Place tank on smooth flat surface.
- b) Lift tank after draining water
- c) Do not drop tank
- d) Install fittings that are supplied with tank by ANTON
- e) Ensure that washers are properly placed.
- f) Tanks can be installed on levelled compacted sand or cement slab. Ensure soft surfaces are compacted very firm.
- g) Ensure the surface is completely clear of stones or branches or any other protrusions, as these will pierce through the base of tank
- h) All tank installation must be positioned in accordance with requirements given in warranty card.
- i) The tank's inlet & outlet pipes should be firmly mounted, not allowing to move, providing adequate allowance for expansion/contraction.
- j) Tank site must be at least the same size as the footprint of tank. Tank site must be of sufficient thickness and suitably reinforced to support the tanks and water weight when full.
- k) Additional holes (inlet/outlet/washout/overflow) or increasing existing hole diameter is not recommended as it would cause tank failure. The inlet/overflow is 32mm, outlet/washout is 50mm.
- l) Do not use welds but use regular plumbing.
- m) Tank should not be subjected to any additional load.
- n) Handle with care, avoid deep scratches, or bruises from rolling.
- o) If exposed to Toxic fumes for long periods the tank lifetime will be reduced.
- p) Tank is meant to carry water only.
- q) Keep tank lid closed after installation.



## TANK SLABS

Table 3

	Tank size (Litre)	Slab thickness (inches)	Reinforcement bar size (mm)	Centre to centre distance (cm)
1	300	3.5	10 and 6	14
2	500	3.5	10 and 6	14
3	1000	4.0	10 and 10	14
4	2000	4.0	12 and 10	14
5	5000	6.0	16 and 12	14
6	10000	15.0	25 and 16	14

\* Proper soil test should be done before following Table No. 3

## BIO -CELL SEWER TREATMENT TANK

Septic holding tank-SHT

Grease and Oil trap-GT

Filter tank - FT

Sewer treatment tank SF

Recommended Rated capacities for Bio-cell tanks

Table 4

Model No	Volume of Tank (Ltr)	Height h (mm)	Diameter D (mm)	Number of users for Five years (Black Water of Houses)
SF 16	1600	1490	1430	4
SF 18	1800	1680	1475	5
SF 20	2000	1830	1475	6
SF 30	3000	1720	2100	10
SF 40	4000	2100	2100	14
SF 60	6000	2600	2100	18
SHT 16	1600	1490	1430	6
SHT 18	1800	1680	1475	7
SHT 20	2000	1830	1475	8
SHT 30	3000	1720	2100	12
SHT 40	4000	2100	2100	20
SHT 60	6000	2600	2100	26
FT 16	1600	1490	1430	18
FT 18	1800	1680	1475	22
FT 20	2000	1830	1475	25
FT 30	3000	1720	2100	41
FT 40	4000	2100	2100	57
FT 60	6000	2600	2100	78
GT 16	1600	1490	1430	
GT 18	1800	1680	1475	
GT 20	2000	1830	1475	
GT 30	3000	1720	2100	
GT 40	4000	2100	2100	
GT 60	6000	2600	2100	



fig. 5

Note : Volume of tank = Effective Volume

## BIO-CELL INSTALLATION LAYOUT

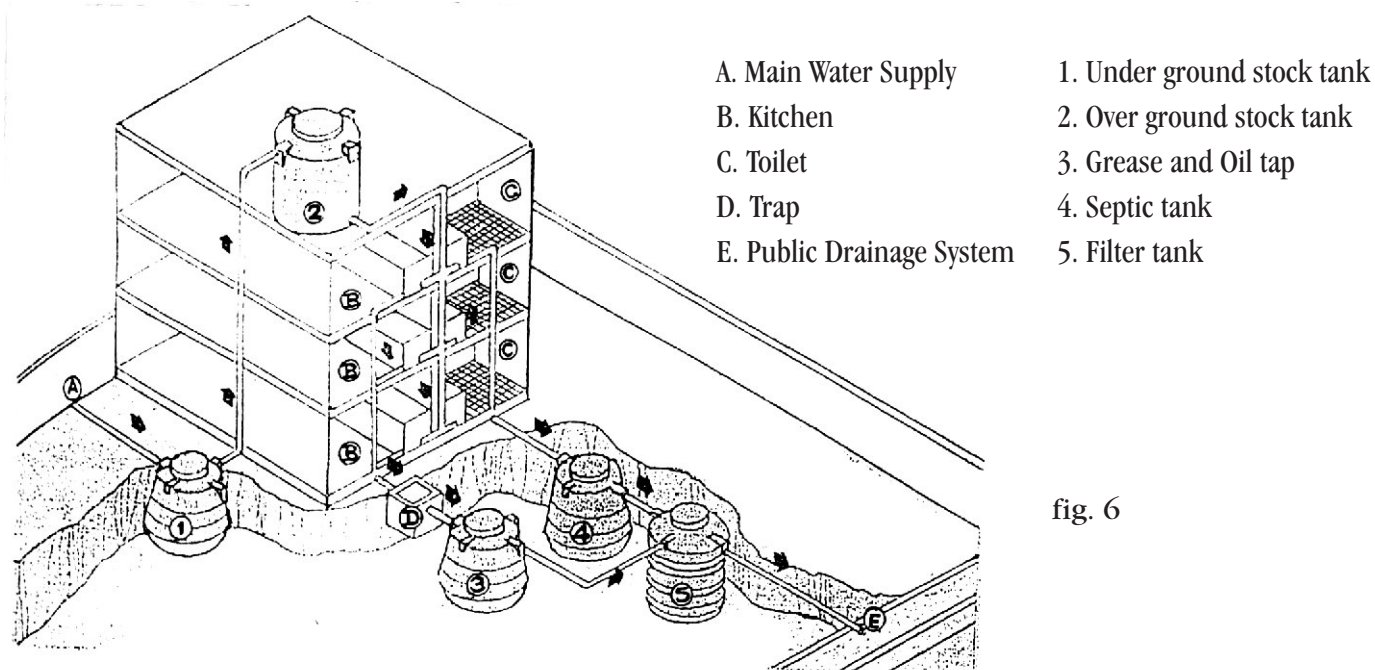

fig. 6

## SEWER TREATMENT TANK

Sri Lanka's total no of households is around 4.5 million, 4% of these households are connected to central sewer treatment facilities. Balance depends on on-site disposal, or sewer is diverted to drains, ditches & canals. Most, septic systems fail, due to:

- a) Urban congestion
- b) High groundwater table/Poor soil
- c) Inappropriate design
- d) Poor maintenance

Treatment tanks that fail would contaminate groundwater, leading to waterborne disease outbreaks & other adverse health effects. The bacteria, protozoa & viruses found in sanitary wastewater can cause disease, including gastrointestinal illness, cholera, hepatitis A & typhoid.

Nitrogen from urine, feces, food waste & cleaning compound are present in wastewater. Consumption of nitrates can cause methemoglobinemia.

Bio-cell tanks are pre-fabricate sewer treatment tanks.

### Advantages

- \* The outlet of the tank can be connected to the Public Drainage System
- \* Unique filtration system purifies the outlet water greatly.
- \* Could be installed closer to the house as there is no seepage of water to the surrounding soil.
- \* Less labour cost and short time to install
- \* Roots of nearby trees cannot be penetrated to the tank since bio-cell tanks are 100% Leakproof.
- \* A soakage pit is not necessarily required therefore less area is required.



## SEWER TREATMENT TANK MODELS

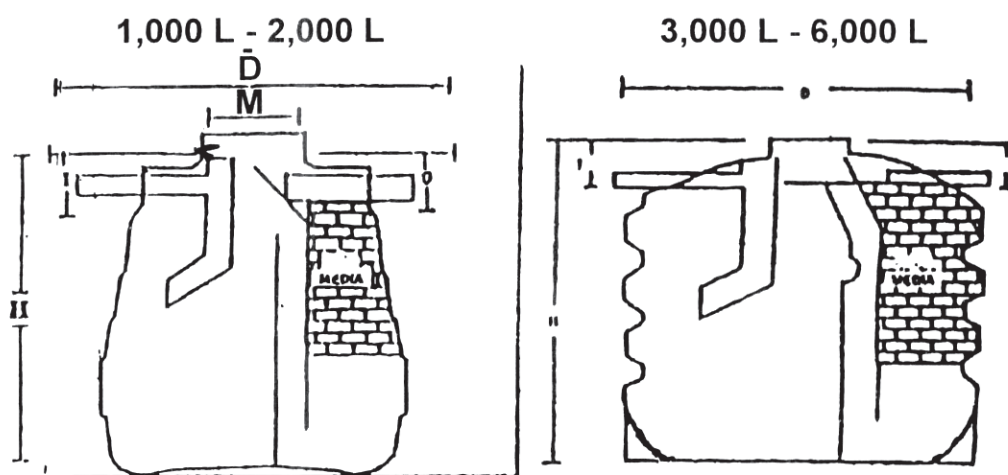

fig. 7

fig. 8

## INSTALLATION OF SEWER TREATMENT TANK

- The inlet of the tank is 110mm. The outlet is 63mm for 1000 to 2000 l and the outlet is 110mm for 3000-6000 l.
- Concrete base should be constructed to support the tank.
- Additional Piling could be required if the tank is to be installed in soft soil or in filled lands.
- Concrete cover is to be constructed to protect the tank, in case the area is dug using a sharp object.
- Brick lining around the lid & manhole cover to be built to prevent entering soil to the tank.  
when the lid is open.
- The inlet of the tank should be connected to the domestic sewer discharge line & the outlet of the tank can be connected to the Public Drainage Line.

- **Vent Hole:** the threaded hole in the tank is the Vent hole. The top of the Vent line should be covered with Mosquito proof wire mesh. The height of the pipe should be 600 mm above the highest vent opening of the building to prevent smell. Alternatively the Vent line of tank can be connected to the house vent line.
- **Manhole Cover:** A steel lid with a water tight seal is ideal, however, a concrete cover may be used as long as it is water tight. Area of cover should be larger than the area of tank lid. This is not provided with the tank.

## INSTALLATION DIAGRAM

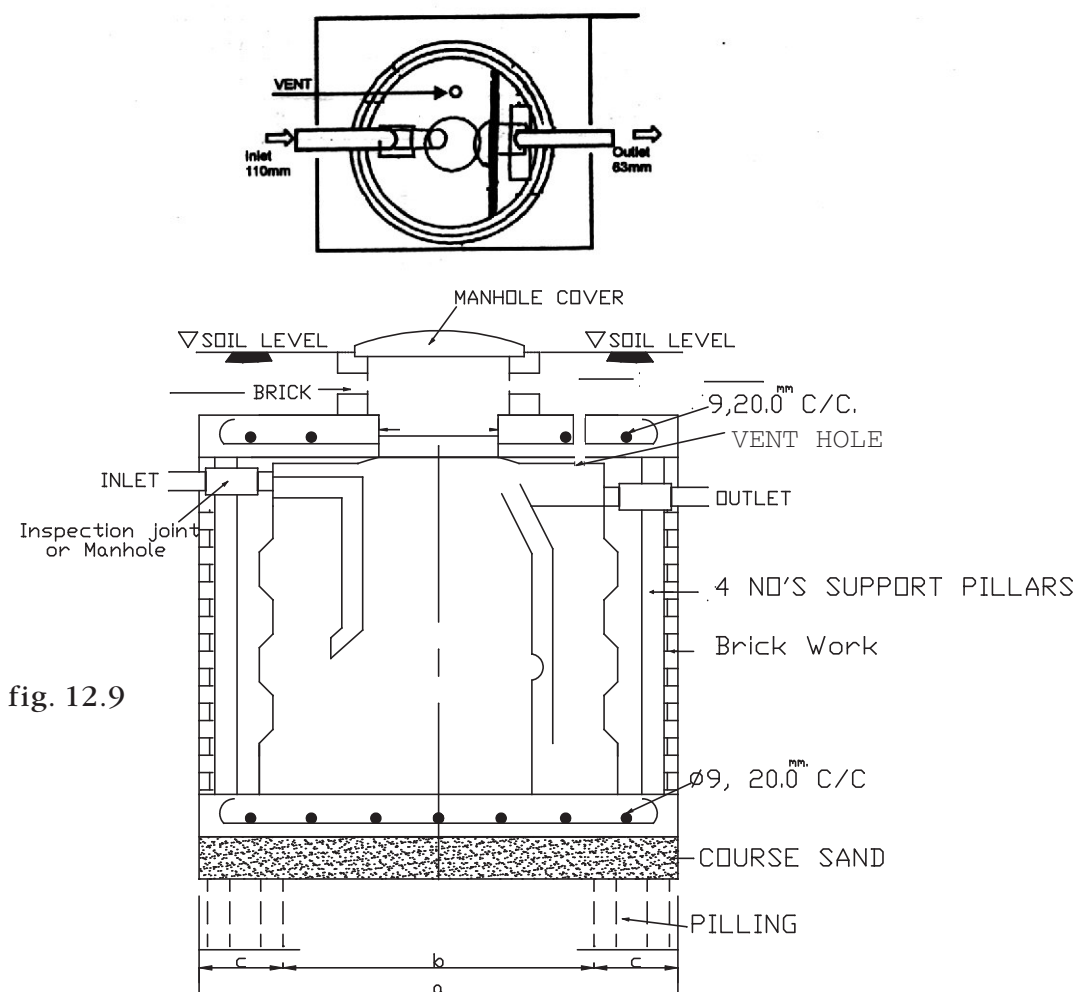

Table 5

Volume of Tank	Pile Number	Type (m)	Dimension of Concrete Base (m)	Dimension (m)		
				a	b	c
1000	4	0.15 x 0.15 x 2.50	1.40 x 1.40	1.40	0.80	0.30
1600	4	0.15 x 0.15 x 3.00	1.60 x 1.60	1.60	1.00	0.30
1800	4	0.15 x 0.15 x 3.50	1.60 x 1.60	1.60	1.00	0.30
2000	4	0.15 x 0.15 x 4.00	1.60 x 1.60	1.60	1.00	0.30
3000	4	0.15 x 0.15 x 4.50	1.80 x 1.80	1.80	1.20	0.30
4000	6	0.15 x 0.15 x 3.00	2.10 x 2.10	2.10	0.75	0.30
6000	6	0.15 x 0.15 x 4.00	2.30 x 2.30	2.30	0.85	0.30

## DIMENSIONS OF CONCRETE BASE

Table 6

Capacity of Tank (l)	Dimensions of Concrete Base (mxm)
1000	1.4 x 1.4
1600	1.6 x 1.6
1800	1.6 x 1.6
2000	1.6 x 1.6
3000	1.8 x 1.8
4000	2.1 x 2.1
6000	2.3 x 2.3

### WARNING:

- \* Grease & Oil should not be discharged into Septic Filter Tanks.
- \* Kitchen waste water lines should not be connected through the Septic-Filter Tanks.
- \* The pipes should be laid in straight lines in both horizontal & vertical planes as far as possible. If bends are unavoidable, they should be of long radius with cleaning eye.
- \* The outlet pipe should be above the public drain level. It is necessary to maintain an inclination from the house to inlet as well as outlet to drain to ensure proper functioning of tank.

## SEWER TREATMENT TANK INSTALLATION LAYOUT

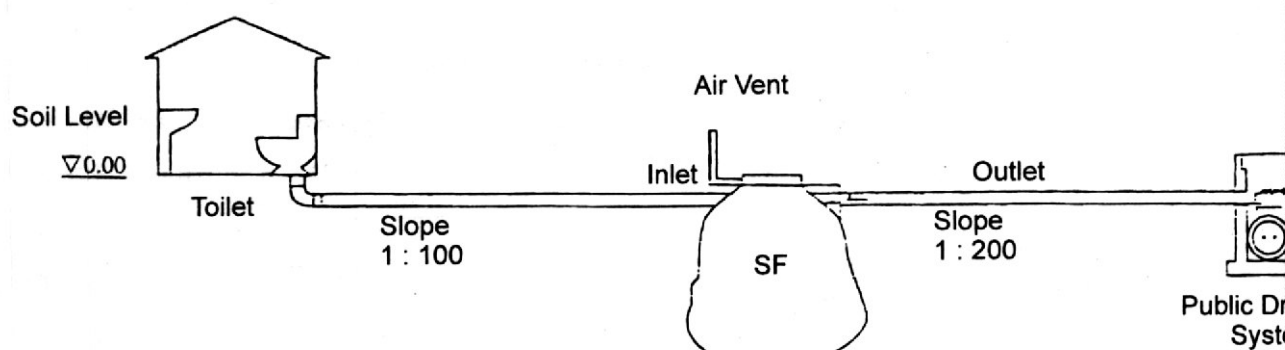

fig. 10

### CLEANING:

To check the level of solid in bio-cell tank use a long rigid stick. Insert into the side where the solids get collected. If 1/3 of the height of the septic tank is filled with solids, should be removed with the assistance of the Gully Sucker could be arranged by the respective Local Council