

# ANTON SOLVENT CEMENT

Anton Solvent Cement is high viscosity slow drying and gives a higher bonding strength and best results in uPVC pipes jointing

It is free flowing, no lumps, easy to apply. Anton Solvent Cement is manufactured to SLS: 935 : 1991 and it complies with all the requirements specified in the standard. It gives satisfactory values for bond strength, hydrostatic burst strength and film properties etc.,

## PROPERTIES OF ANTON SOLVENT CEMENT

Bond Strength 6.5 MPa

Burst Strength 4.5 MPa



### Available bottle sizes.

|      |      |       |       |       |        |
|------|------|-------|-------|-------|--------|
| 25 g | 50 g | 100 g | 250 g | 500 g | 1000 g |
|------|------|-------|-------|-------|--------|



### BRUSHES RECOMMENDED FOR SOLVENT WELDING

Table 1

|   |   |   |
|---|---|---|
| <br>1/2" | <br>3/4" | <br>1 1/2" |
| For pipes<br>from 20mm<br>to 25mm   | For pipes<br>from 32mm<br>to 63mm   | For pipes<br>from 75mm<br>to 160mm  |

### AVERAGE NUMBER OF JOINTS MADE WITH 1Kt. OF CEMENT

Table 2

| Dia of Pipe | Number of joints |
|-------------|------------------|
| 20 - 1/2"   | 500              |
| 25 - 3/4"   | 450              |
| 32 - 1"     | 400              |
| 40 - 1 1/4" | 300              |
| 50 - 1 1/2" | 200              |
| 63 - 2"     | 140              |
| 75 - 2 1/2" | 90               |
| 90 - 3"     | 60               |
| 110 - 4"    | 40               |
| 160 - 6"    | 15               |



ANTON SOLVENT CEMENT CONFORMS TO SLS : 935 : 1991

# PLUMBING TECHNIQUES

Anton uPVC pipes and fittings allow various types of connections depending on the demands of the pipe system.

## CONNECTION SYSTEMS

- connection by solvent welding
- connection by Threading
- connection by union or flanges
- connection by saddle joints
- connection by integral rubber ring joints

## SOLVENT WELDING

Joining pipes and fittings by solvent welding is the speediest and most secure. However, to obtain the best results the following instructions must be followed.

It is advisable to choose the most suitable type of cement.

Special features and tolerances are maintained in ANTON pipes and fittings to allow solvent welding. Solvent Welding joints are recommended for pipe diameters up to 315 mm.

Socket of a pipe or socket of a fitting has a (+) tolerance on its mid point diameter (measured at mid point of socket length) and a included angle of  $0^{\circ} 0' - 0^{\circ} 30'$ .

uPVC pipe too has a (+) tolerance on O.D.

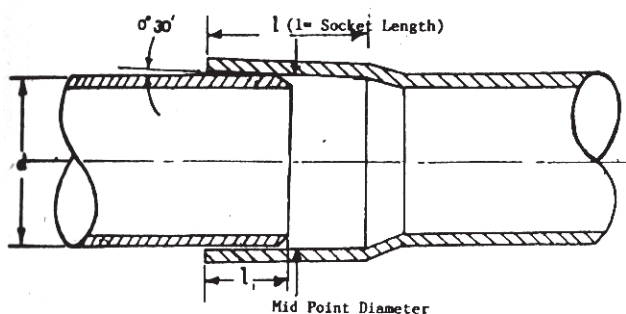

fig. 1

When the pipe inserts to the socket, it freely goes upto the point where OD of the pipe and ID of the socket equals. This length is lie as per the Diagram (fig, 1)

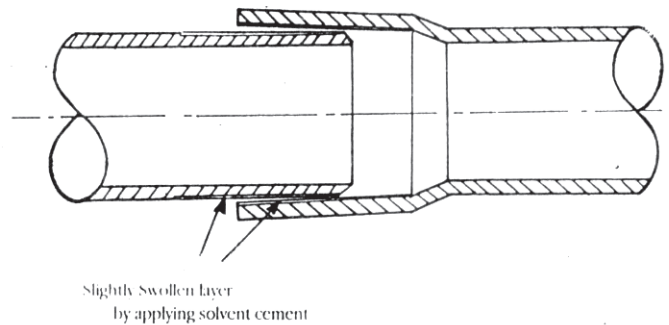

fig. 2

The inside surface of the socket and the outer surface of the pipe produces a slightly swollen layer by applying solvent cement. This change of property eases the pipe to be inserted further and whole socket length will then be engaged.

This special features and precision clearances of ANTON pipes and fittings construct perfect & strong bonded solvent joints.

## PROCEDURE

Solvent welding is easy to do. No much tools are required.

Cut the pipe at right angles in the length desired and bevel the edges, with a file or knife.

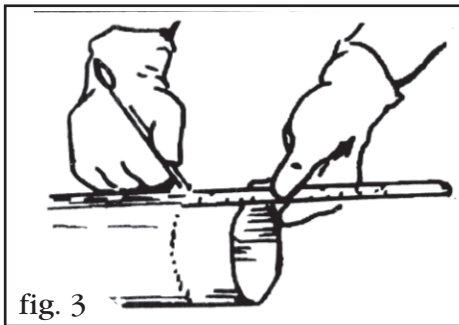

fig. 3

Mark the portion of pipe to be covered with cement

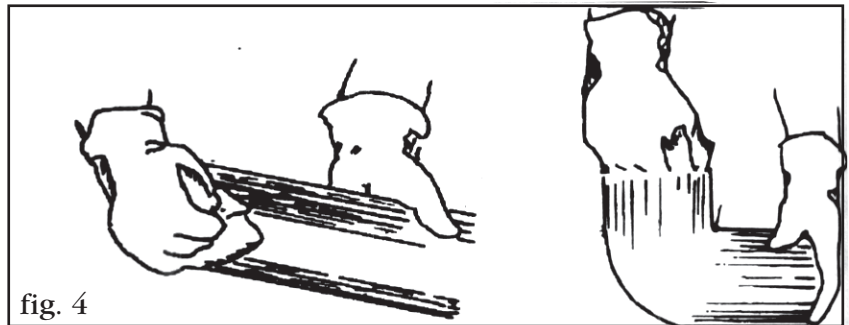

fig. 4

Remove all traces of grease or dust at the ends of the pipe, and in the internal parts of joints by means of cloth soaked in meathylated spirits.

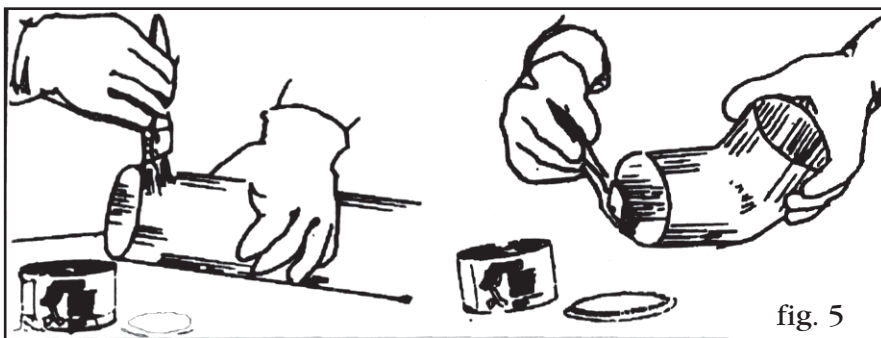

fig. 5

Spread the cement chosen liberally at the end of the pipe previously marked, and on the internal part of the socket of the joint or of the valve, using a brush of suitable dimensions.

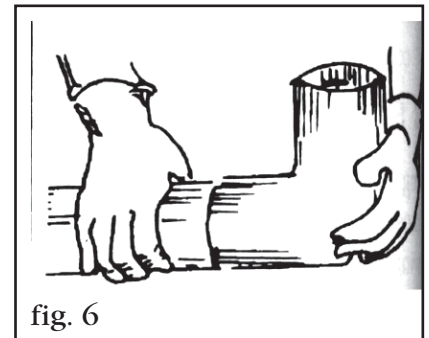

fig. 6

Insert pipe to the joint or to the valve turning gently.

**N. B. - Although the joint will have a good bond within a few minutes, wait for at least two hours per every atmosphere of pressure before putting the plant into operation, culminating in a very high bond strength.**

Recommended socket length on pipe to be prepared for the joints are as follows.

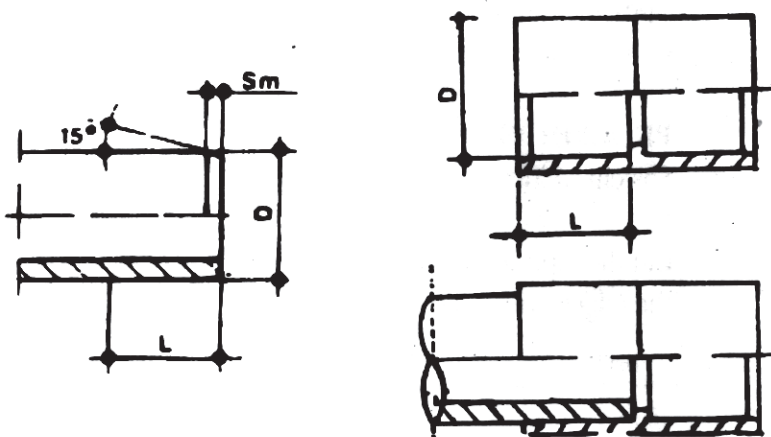

fig. 7

Table 3

| D(mm) | L    | Sm |
|-------|------|----|
| 20    | 16   |    |
| 25    | 18.5 |    |
| 32    | 22   |    |
| 40    | 26   | 3  |
| 50    | 31   |    |
| 63    | 37.5 |    |
| 75    | 43.5 |    |
| 90    | 51   |    |
| 110   | 61   | 5  |
| 160   | 86   |    |

# THREADED JOINTS

Joints in uPVC of the threaded type are adequate for connecting thick wall pipe.

The screw threads conform to SLS 282:1974 Parallel threads and Tapered threads.

To join threaded pieces the following instructions must be followed:



1. To ensure a water-tight joint, it is necessary to put on the surface of the male thread a thin layer of non-sintered, Thread sealing tape (1A.1B fig 8) The tape, with its self lubricating characteristics, facilitates screwing and acts as a packing securing the joint. The use of hemp, tow, threads and varnishes, normally used for metallic joints must be avoided. Infact the forced compression of these materials can cause a breakage of the part during the installation phase or subsequently during operation.

2. Screw completely but not excessively tight. (2A. 2B-fig 8) It is preferable to use special strap wrenches. However, if metal wrenches are used, it is advisable to place a piece of cloth or other soft material between the wrench and the part to be screwed, to avoid scratching the surface.

**N.B. • During the screwing two difficulties can occur:**

(a) Screw too loose (Insufficient tape) ,

(b) Screw too tight (excessive tape)

In case of (a) it will be necessary to use a further layer of tape and in case of (b) it will be necessary to eliminate all the tape, and to repeat the taping operation reducing the number of layers.

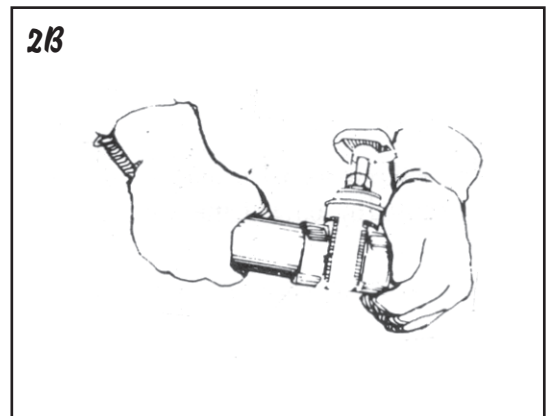
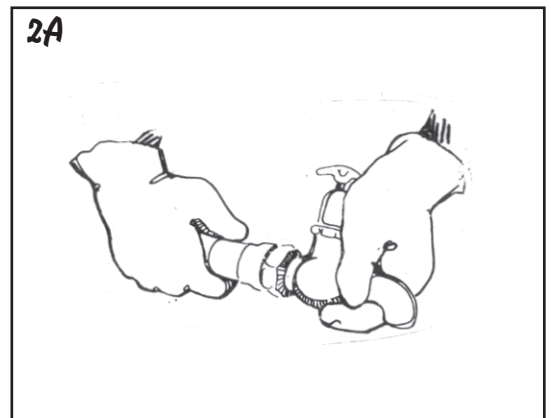
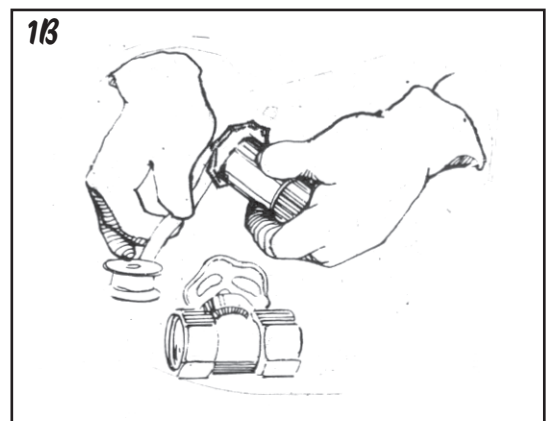
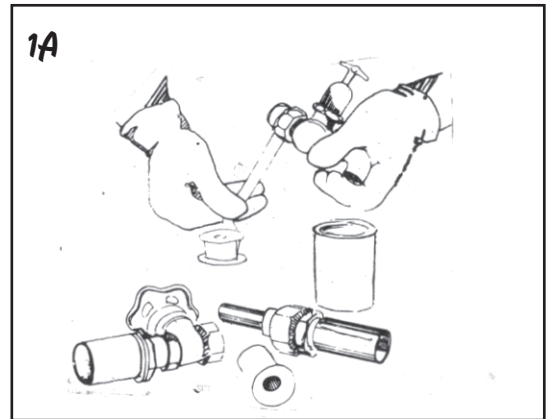

fig. 8